

AVTECH ELECTROSYSTEMS LTD.

**NANOSECOND WAVEFORM ELECTRONICS
ENGINEERING - MANUFACTURING**

□ P.O. BOX 265
OGDENSBURG
NEW YORK
13669
(315) 472-5270

Y
□ BOX 5120 STN. "F"
OTTAWA, ONTARIO
CANADA K2C 3H4
(613) 226-5772
TELEX 053-4591

INSTRUCTIONS

MODEL AV-100

S.N.:

WARRANTY

Avtech Electrosystems Ltd. warrants products of its manufacture to be free from defects in material and workmanship under conditions of normal use. If, within one year after delivery to the original owner, and after prepaid return by the original owner, this Avtech product is found to be defective, Avtech shall at its option repair or replace said defective item. This warranty does not apply to units which have been disassembled, modified or subjected to conditions exceeding the applicable specifications or ratings. This warranty is the extent of the obligation or liability assumed by Avtech with respect to this product and no other warranty or guarantee is either expressed or implied.

A)

TEST ARRANGEMENT AND OPERATING INSTRUCTIONS

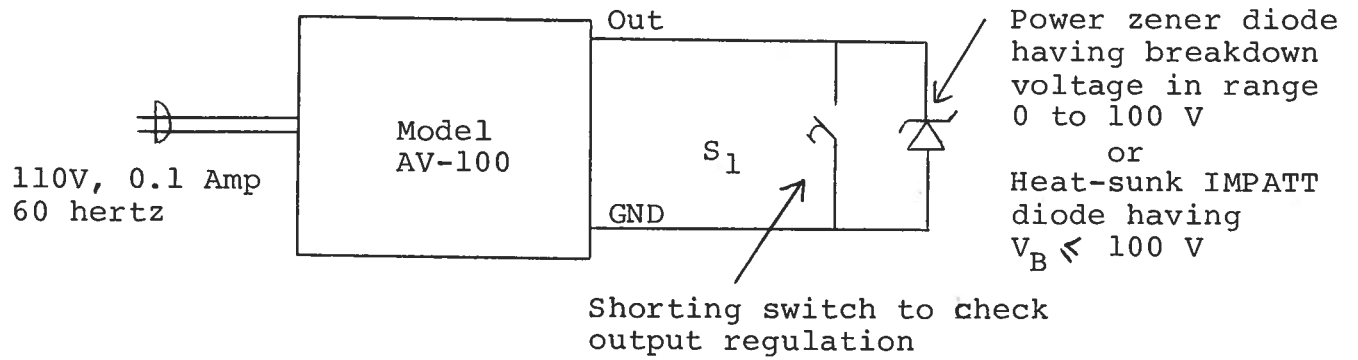

- 1) Set the ON-OFF switch in the OFF position and rotate the front panel pot control to maximum counter clockwise. Connect the diode load and shorting switch S, as shown and connect to 60 Hz outlet.
- 2) Switch ON-OFF switch to ON position. The meter should read about 8.0 mA. Clockwise rotation of the pot will increase the output current to a maximum of at least 50 mA (for load voltages in the range of 0 to 100 volts).
- 3) With the output current set at any value in the range of 8 to 50 mA, the change in meter reading should be barely detectable when the shorting switch S, is alternately opened and closed.
- 4) If the load is opened circuited or if the load voltage exceeds approximately 105 volts, the ammeter will read 0 mA.
- 5) If the output current can be readily varied over the range of 8 to 50 mA via the pot control and if the output regulation is within specifications, the AV-100 unit can be safely used to bias an IMPATT device.

B)

CIRCUIT DIAGRAM

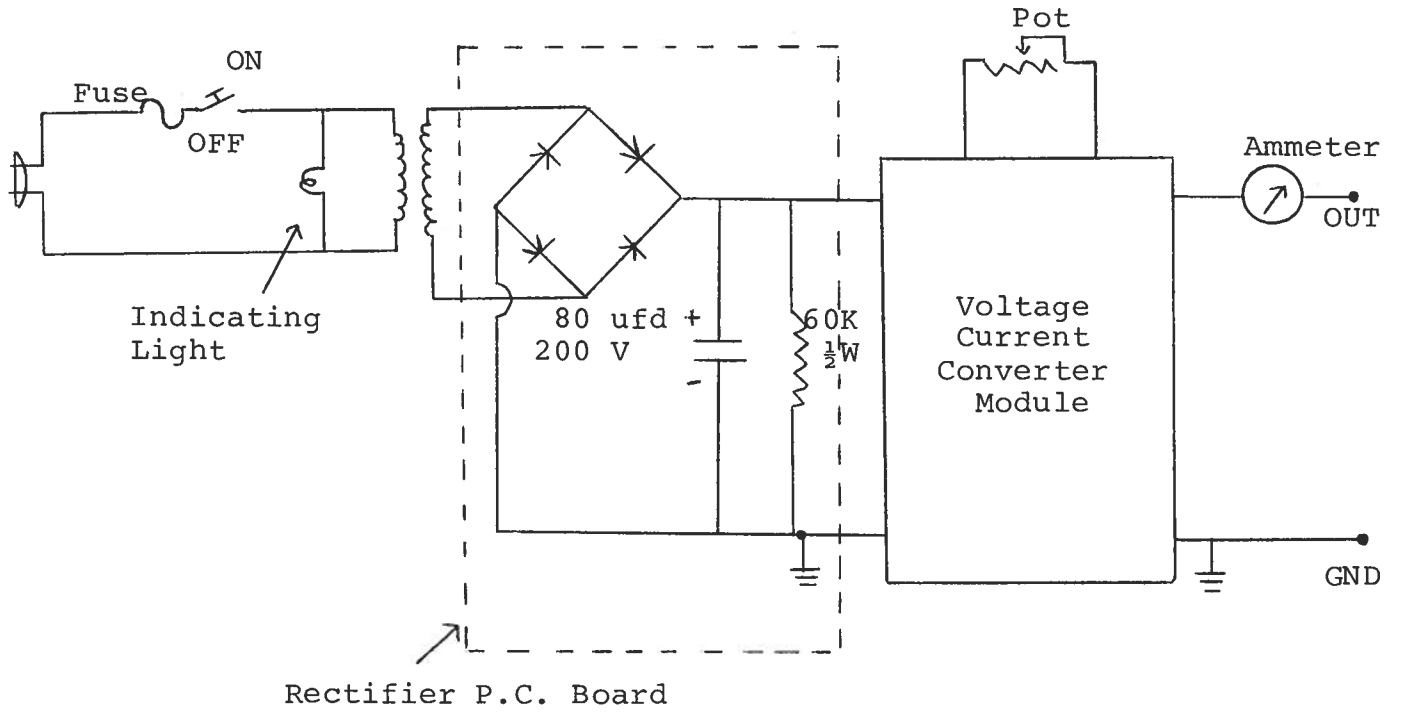

VCCM
Pin connections
(Top view)

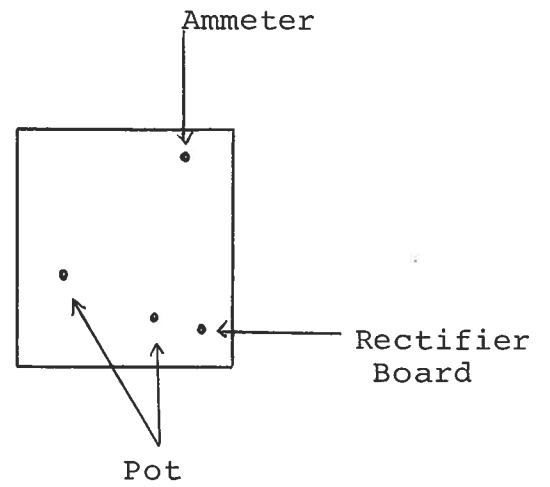

C)

REPAIR PROCEDURE

In the event that the AV-100 unit does not provide an output or is not operating properly as a constant current source, the cause and defective components may be identified as follows:

- 1) Disconnect instrument from 60 Hz source.
- 2) Confirm that fuse is not blown.
- 3) Connect a load similar to that shown under operating instructions. Remove eight screws which attach the instrument back panel thereby exposing the instrument interior. CAUTION: Points having potentials as high as 180 V are exposed in the interior.
- 4) Connect to a 60 Hz source and set ON-OFF switch to ON position and set front panel pot control to mid-range position. Attach scope probe or voltmeter probe to line connecting positive terminal of rectifier filter capacitor to voltage to current converter module. This voltage should be in the range of +150 to +180 volts. If the voltage is below this range, unsolder the connection of the voltage to current converter module and measure the rectifier output voltage again. If it is still below 150 volts then the rectifier board or transformer is at fault and should be repaired or replaced (see Parts List). If the output voltage is within the 150 to 180 volt range then the voltage to current converter module is at fault and should be replaced. If it was necessary to repair or replace the rectifier board, check the operation of the voltage to current converter module before reconnecting the two. This can be performed by applying a DC potential of +160 volts from a lab power supply to the input terminal of the converter. If the input to the converter is not shorted and draws a current only slightly larger than the output load current (as indicated by the AV-100 ammeter) then the module is servicable and the rectifier and module may be safely reconnected. However, if the input current is very high or very low, then the module should be replaced.

D)

PARTS LIST

Part	<u>Manufacturer and Model No.</u>
Power transformer:	Signal Transformer Type 241-5-120
Bridge rectifier:	General Instrument KBPO2 or equivalent
Filter capacitor:	Phillip 40 ufd, 200 V. 436 AR/L40
Printed Circuit board:	Avtech Part No. AV-100PCB
Voltage to current converted module:	Avtech Part No. AV-100-VCCM
Ammeter:	Modutec, Model OMC-DMA-050
Pot:	1000 ohms, 1/4 Watt Ohmite RV6NAYS102A or equivalent

CONSTANT CURRENT SUPPLY

PERFORMANCE CHECK

Model:

S.N.:

Date:

- a) Max. output current:
(80 V load)
- b) Max. output current:
(short circuited load)
- c) Min. output current:
(80 V load)
- d) Min. output current:
(short circuited load)
- e) Output current change for
load voltage change of 80 V:

File in Word as of Oct 1991

File: c:\instruct\AV-1100.DOC

Note: File has been adjusted



INSTRUMENT CURRENT SUPPLY

REFERENCE CHECK

Model:

1.16:

D-1a:

a) Input current (load)
100 V (load)

b) Input current (load)
100 V (load)

c) Input current (load)
100 V (load)

d) Input current (load)
100 V (load)

e) Input current (load)
100 V (load)