



AVTECH ELECTROSYSTEMS LTD.

NANOSECOND WAVEFORM ELECTRONICS
SINCE 1975

P.O. BOX 265
OGDENSBURG, NY
U.S.A. 13669-0265
TEL: (315) 472-5270
FAX: (613) 226-2802

TEL: 1-800-265-6681
FAX: 1-800-561-1970

e-mail: info@avtechpulse.com
<http://www.avtechpulse.com/>

BOX 5120, LCD MERIVALE
OTTAWA, ONTARIO
CANADA K2C 3H4
TEL: (613) 226-5772
FAX: (613) 226-2802

INSTRUCTIONS

MODEL AVX-DD-A1-PS

0 TO 999.999 μ s

DIGITAL DELAY GENERATOR

SERIAL NUMBER: _____

WARRANTY

Avtech Electrosystems Ltd. warrants products of its manufacture to be free from defects in material and workmanship under conditions of normal use. If, within one year after delivery to the original owner, and after prepaid return by the original owner, this Avtech product is found to be defective, Avtech shall at its option repair or replace said defective item. This warranty does not apply to units which have been disassembled, modified or subjected to conditions exceeding the applicable specifications or ratings. This warranty is the extent of the obligation assumed by Avtech with respect to this product and no other warranty or guarantee is either expressed or implied.

TECHNICAL SUPPORT

Phone: 613-226-5772 or 1-800-265-6681

Fax: 613-226-2802 or 1-800-561-1970

E-mail: info@avtechpulse.com

World Wide Web: <http://www.avtechpulse.com>

TABLE OF CONTENTS

WARRANTY	2
TECHNICAL SUPPORT	2
TABLE OF CONTENTS	3
INTRODUCTION	5
AVAILABLE OPTIONS	5
SPECIFICATIONS	6
EC DECLARATION OF CONFORMITY	7
INSTALLATION	8
VISUAL CHECK	8
POWER RATINGS	8
CONNECTION TO THE POWER SUPPLY	8
ENVIRONMENTAL CONDITIONS	8
FUSES	9
AC FUSE REPLACEMENT	9
DC FUSE REPLACEMENT	10
FUSE RATINGS	10
FRONT PANEL CONTROLS	11
REAR PANEL CONTROLS	13
GENERAL INFORMATION	14
BASIC OPERATION	14
CALIBRATION	15
THEORY OF OPERATION	15
ACCURACY	16
DRIFT	16
MINIMIZING WAVEFORM DISTORTIONS	17
USE 50Ω TRANSMISSION LINES AND LOADS	17
USE LOW-INDUCTANCE LOADS	17
MECHANICAL INFORMATION	18
TOP COVER REMOVAL	18
ELECTROMAGNETIC INTERFERENCE	18
MAINTENANCE	19
REGULAR MAINTENANCE	19

CLEANING..... 19
PERFORMANCE CHECK SHEET.....20

Manual Reference: /fileserv1/officefiles/instructword/avx-dd/AVX-DD-A1-PS.sxw.
Copyright © 2003 Avtech Electrosystems Ltd, All Rights Reserved.

INTRODUCTION

The AVX-DD-A1-PS is a digital delay generator. The delay of each channel can be set between 0 and 999.999 μ s, in 1 ns increments. (Models with the -HR option have an improved resolution of 0.1 ns). The insertion delay is less than 40 ns.

The instrument is triggered by TTL-level pulses. The output pulse is also TTL, and it can drive loads of 50 Ω and higher. The output pulse width is variable from 100 ns to 1 μ s.

This instrument is intended for use in research and development laboratories.

AVAILABLE OPTIONS

The AVX-DD-A1-PS is available with several options:

-HR Option: reduces the delay increment from 1 ns to 0.1 ns.

-TC Option: adds a second independent delay channel (with separate input and output connections, and separate delay controls).

SPECIFICATIONS

Model:	AVX-DD-A1-PS
Variable delay range:	0 to 999.999 us
Delay resolution:	1 ns 0.1 ns optional ²
Jitter ³ : (trig in to pulse out)	± 40 ps ± 0.0005% of delay.
Accuracy (excluding insertion delay):	± 10 ns ± 0.5% of delay.
Number of output channels:	One standard, Two optional ¹
Delay controls:	Thumbwheel controls
Insertion delay:	≤ 40 ns
Rise time, fall time:	≤ 10 ns
Display:	Thumbwheel controls
Output amplitude:	+3V (TTL) will drive 50 Ohm loads
Trigger required:	+ 5 Volt, PW > 50 ns
OUT pulse width:	100 ns to 1 us, one-turn control
Max duty cycle:	80%
PRF:	0 to 5 MHz
Connectors:	BNC
Power requirement:	120/240 Volts (switchable) 50 - 60 Hz
Dimensions:	Standard units: 100 x 215 x 375 mm (3.9" x 8.5" x 14.8") With -TC option: 100 x 430 x 375 mm (3.9" x 17" x 14.8")

- 1) To specify the two output channel option, add the suffix -TC to the model number.
- 2) To specify the 0.1 ns resolution option, add the suffix -HR to the model number.
- 3) Jitter = standard deviation of the measured delay during a one second interval.

EC DECLARATION OF CONFORMITY

We

Avtech Electrosystems Ltd.
P.O. Box 5120, LCD Merivale
Ottawa, Ontario
Canada K2C 3H4

declare that this pulse generator meets the intent of Directive 89/336/EEC for Electromagnetic Compatibility. Compliance pertains to the following specifications as listed in the official Journal of the European Communities:

EN 50081-1 Emission

EN 50082-1 Immunity

and that this pulse generator meets the intent of the Low Voltage Directive 72/23/EEC as amended by 93/68/EEC. Compliance pertains to the following specifications as listed in the official Journal of the European Communities:

EN 61010-1:2001 Safety requirements for electrical equipment for measurement, control, and laboratory use



INSTALLATION

VISUAL CHECK

After unpacking the instrument mainframe and the transformer module, examine to ensure that they have not been damaged in shipment. Visually inspect all connectors, knobs, and handles. Confirm that a power cord and an instrumentation manual (this manual), are with the instrument. If the instrument has been damaged, file a claim immediately with the company that transported the instrument.

POWER RATINGS

This instrument is intended to operate from 115 / 230 V \pm 10%, 50-60 Hz. The instrument automatically switches between these two levels. Note, however, that different fuses are required for the two ranges, as described in the "FUSES" section.

The maximum power consumption is 57 Watts. This instrument is an "Installation Category II" instrument, intended for operation from a normal single-phase supply.

CONNECTION TO THE POWER SUPPLY

An IEC-320 three-pronged recessed male socket is provided on the back panel for AC power connection to the instrument. One end of the detachable power cord that is supplied with the instrument plugs into this socket. The other end of the detachable power cord plugs into the local mains supply. Use only the cable supplied with the instrument. The mains supply must be earthed, and the cable used to connect the instrument to the mains supply must provide an earth connection. (The supplied cable does this.)

ENVIRONMENTAL CONDITIONS

This instrument is intended for use under the following conditions:

- a) indoor use;
- b) altitude up to 2 000 m;
- c) temperature 5 °C to 40 °C;
- d) maximum relative humidity 80 % for temperatures up to 31 °C decreasing linearly to 50 % relative humidity at 40 °C;
- e) Mains supply voltage fluctuations up to \pm 10 % of the nominal voltage;
- f) no pollution or only dry, non-conductive pollution.

FUSES

This instrument contains four fuses. All are accessible from the rear-panel. Two protect the AC prime power input, and two protect the internal DC power supplies. The locations of the fuses on the rear panel are shown in the figure below:

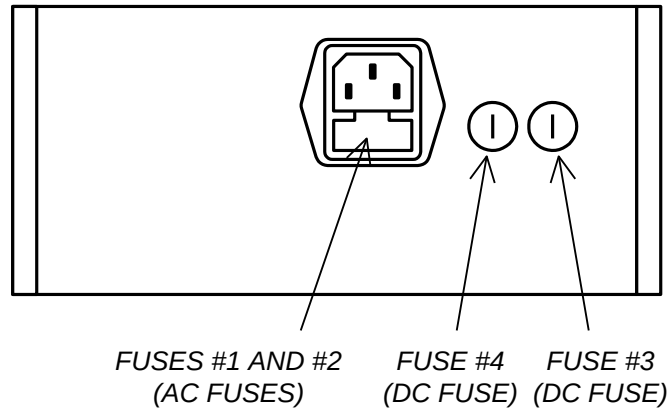

AC FUSE REPLACEMENT

To physically access the AC fuses, the power cord must be detached from the rear panel of the instrument. The fuse drawer may then be extracted using a small flat-head screwdriver, as shown below:

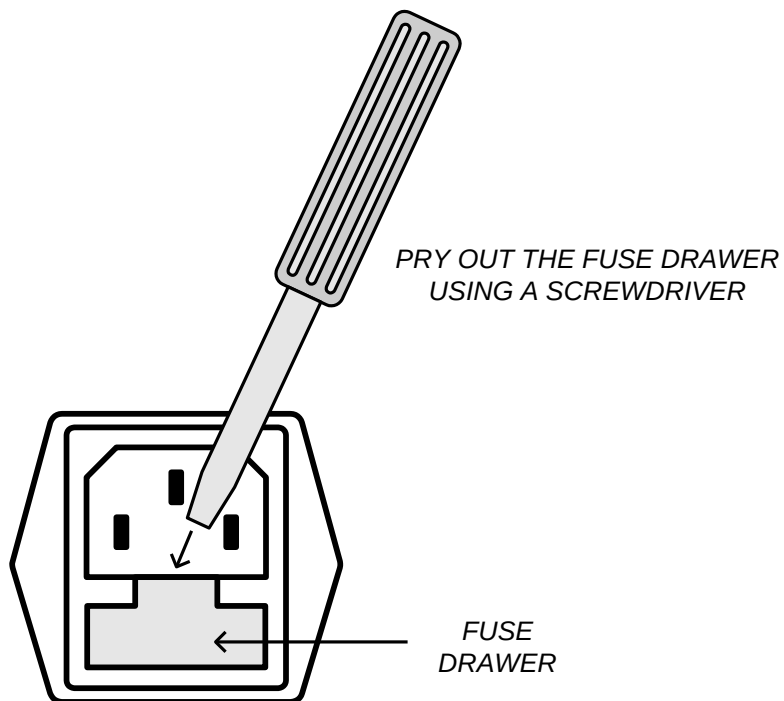

DC FUSE REPLACEMENT

The DC fuses may be replaced by inserting the tip of a flat-head screwdriver into the fuse holder slot, and rotating the slot counter-clockwise. The fuse and its carrier will then pop out.

FUSE RATINGS

The following table lists the required fuses:

Fuses	Mains Voltage	Rating	Case Size	Manufacturer's Part Number (Wickmann)	Distributor's Part Number (Digi-Key)
#1, #2 (AC)	115 V	0.5A, 250V, Time-Delay	5 x 20 mm	1950500000	WK5041-ND
	230 V	0.25A, 250V, Time-Delay	5 x 20 mm	1950250000	WK5035-ND
#3 (DC)	115/230V	0.8A, 250V, Time-Delay	5 x 20 mm	1950800000	WK5046-ND
#4 (DC)	Not used. A spare 0.8A fuse is installed in this position.				

The fuse manufacturer is Wickmann (<http://www.wickmann.com/>).

Replacement fuses may be easily obtained from Digi-Key (<http://www.digikey.com/>) and other distributors.

FRONT PANEL CONTROLS

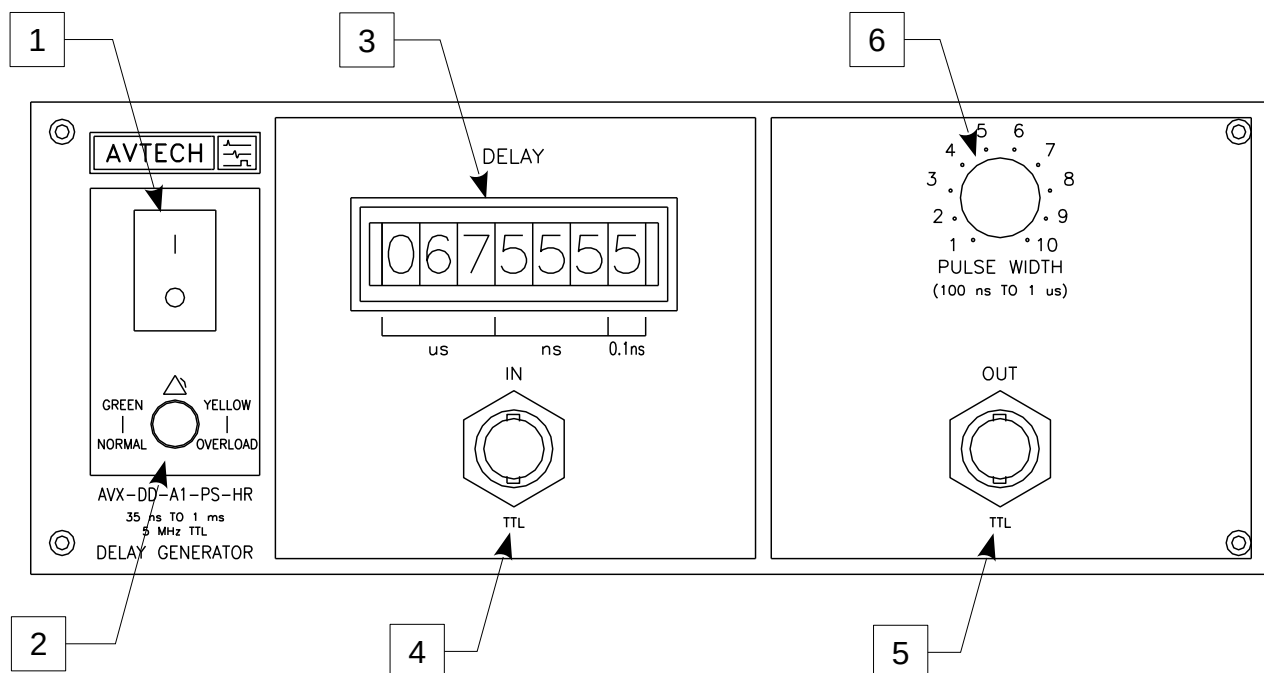

- 1) **POWER Switch**. This is the main power switch. When turning the instrument on, there may be a delay of several seconds before the instrument appears to respond.
- 2) **OVERLOAD Indicator**. When the instrument is powered, this indicator is normally green, indicating normal operation. If this indicator is yellow, an internal automatic overload protection circuit has been tripped. If the unit is overloaded (by operating at an exceedingly high duty cycle or by operating into a very low impedance), the protective circuit will disable the output of the instrument and turn the indicator light yellow. The light will stay yellow (i.e. output disabled) for about 5 seconds after which the instrument will attempt to re-enable the output (i.e. light green) for about 1 second. If the overload condition persists, the output will be disabled again (i.e. light yellow) for another 5 seconds. If the overload condition has been removed, the instrument will resume normal operation.

This overload indicator may flash yellow briefly at start-up. This is not a cause for concern.

Note that the output stage will safely withstand a short-circuited load condition.

- 3) **DELAY Setting**. This thumbwheel switch controls the delay between the IN signal and the output on the OUT connector. (The "0.1 ns" section is only present on

units with the -HR option.)

- 4) IN Connector. The TTL-level (i.e., 0 and 3-5V) input trigger is applied to this connector. The input impedance is greater than 500 Ω . (Depending on the length of cable attached to this input, and the source driving it, it may be desirable to add a coaxial 50 Ohm terminator to this input to provide a proper transmission line termination. The Pasternack (www.pasternack.com) PE6008-50 BNC feed-thru 50 Ohm terminator is suggested for this purpose.)
- 5) OUT Connector. This BNC connector provides the delayed output signal, into load impedances of 50 Ω or higher.
- 6) Pulse Width Control. This dial controls the pulse width of the output signal.

REAR PANEL CONTROLS

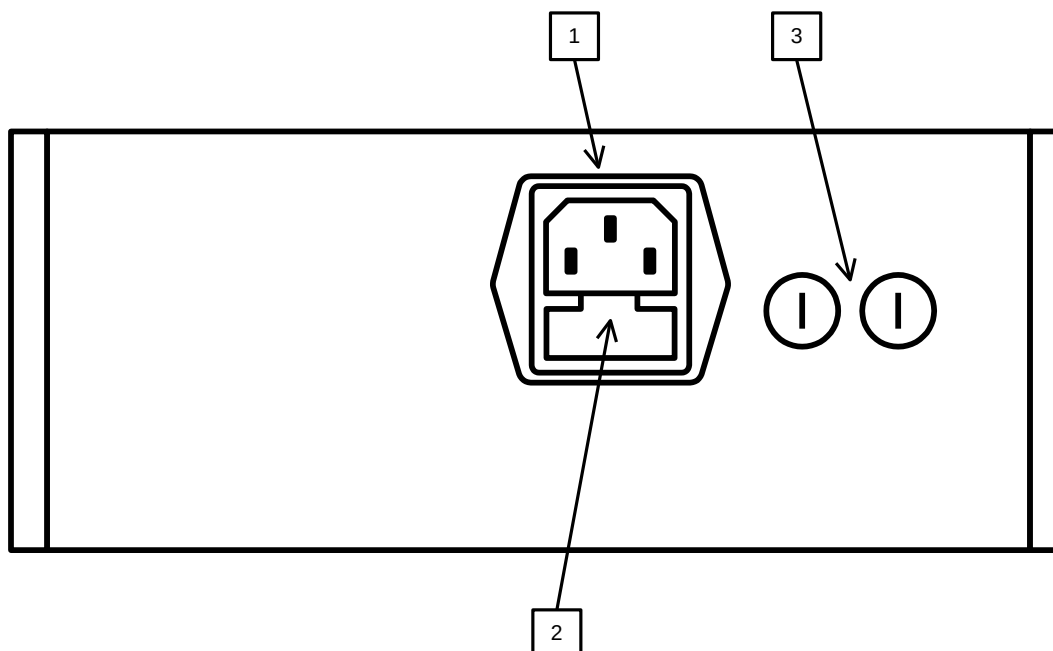

1. AC POWER INPUT. An IEC-320 C14 three-pronged recessed male socket is provided on the back panel for AC power connection to the instrument. One end of the detachable power cord that is supplied with the instrument plugs into this socket.
2. AC FUSE DRAWER. The two fuses that protect the AC input are located in this drawer. Please see the “FUSES” section of this manual for more information.
3. DC FUSES. These two fuses protect the internal DC power supplies. Please see the “FUSES” sections of this manual for more information.

GENERAL INFORMATION

BASIC OPERATION

The output is delayed relative to the input, as shown below. The delay is the sum of the insertion delay (< 40 ns) and the programmed delay, set on the front panel thumbwheel switches.

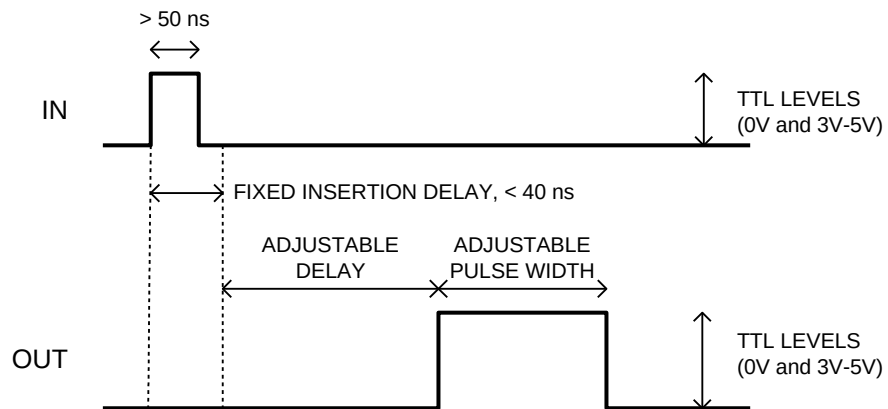

The output will drive loads as low as 50Ω .

CALIBRATION

THEORY OF OPERATION

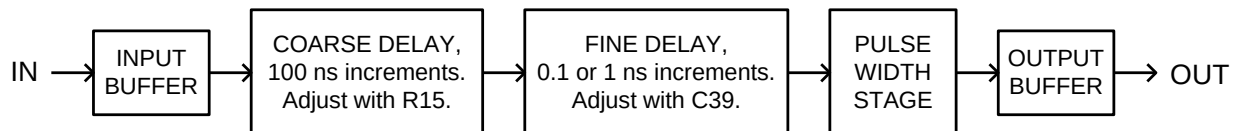

The AVX-DD-A1-PS uses two delay circuits: the “coarse delay” circuit delays the pulse in increments of 100 ns (i.e., the first 4 digits of the thumbwheel switch control this section.) The “fine delay” circuit handles the remaining delay, in the range of 0 to 99.9 ns. Both the coarse and fine circuits are adjustable within a narrow range, to allow calibration and synchronization.

To calibrate the coarse section, measure the different delays obtained when you switch between settings of 0 and 900 us. The difference between the two measurements should be exactly 900.0 us. If it is not, remove the top cover and locate the trimming potentiometer (or “trimpot”) R15 on the appropriate circuit board (see the diagram below). Using a small slot screwdriver, rotate the twelve-turn brass screw on the trimpot until a delay difference of 900.0 us is obtained.

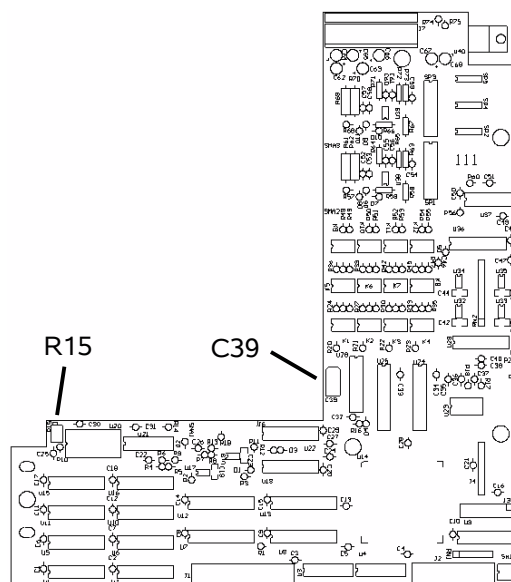

To calibrate the fine section, observe the different delays when you switch between settings of 199.0 ns and 200.0 ns. The difference between the two measurements should be 1.0 ns. If it is not, remove the top cover and locate the variable capacitor C39 on the appropriate circuit board (see the diagram below). Using a small slot screwdriver, rotate the brass screw on the capacitor until a delay increment of 1.0 ns is

obtained. Note that the measurements will not be correct while the screwdriver is touching C39. Take your measurements after making each adjustment.

ACCURACY

The coarse delay section uses a 10 MHz oscillator that is triggered by the input pulse. This produces the 100 ns steps used to delay the output. However, the first oscillation of the oscillator is slightly longer (108 ns) than all following oscillations (100 ns). This introduces some error for operation with settings below 100 ns, and this accounts for the bulk of the fixed portion of the “ $\pm 10 \text{ ns} \pm 0.5\%$ of delay” accuracy specification. The percentage portion is determined by the accuracy of the 100 ns oscillations, which can be adjusted using R15. In practice, the 0.5% figure can be reduced by carefully adjusting R15.

DRIFT

The AVX-DD-A1-PS will benefit from a warm-up time of 30 minutes. This will minimize delay drift.

MINIMIZING WAVEFORM DISTORTIONS

USE 50Ω TRANSMISSION LINES AND LOADS

Connect the load to the pulse generator with 50Ω transmission lines (e.g. RG-58 or RG-174 cable).

This instrument requires a 50Ω load for proper operation. It will not properly drive a high-impedance load. The output stage will be damaged if it is operated into an open circuit (or any other high impedance). Failures due to improper output loading are not covered by the warranty.

USE LOW-INDUCTANCE LOADS

Lenz's Law predicts that for an inductive voltage spike will be generated when the current through an inductance changes. Specifically, $V_{\text{SPIKE}} = L \times di_{\text{LOAD}}/dt$, where L is the inductance, i_{LOAD} is the load current change, and t is time. For this reason, it is important to keep any parasitic in the load low. This means keeping wiring short, and using low inductance components. In particular, wire-wound resistors should be avoided.

MECHANICAL INFORMATION

TOP COVER REMOVAL

If necessary, the interior of the instrument may be accessed by removing the four Phillips screws on the top panel. With the four screws removed, the top cover may be slid back (and off).

Always disconnect the power cord before opening the instrument.

There are no user-adjustable internal circuits. For repairs other than fuse replacement, please contact Avtech (info@avtechpulse.com) to arrange for the instrument to be returned to the factory for repair.

⚠ Caution: High voltages are present inside the instrument during normal operation. Do not operate the instrument with the cover removed.

ELECTROMAGNETIC INTERFERENCE

To prevent electromagnetic interference with other equipment, all used outputs should be connected to shielded 50Ω loads using shielded 50Ω coaxial cables. Unused outputs should be terminated with shielded 50Ω coaxial terminators or with shielded coaxial dust caps, to prevent unintentional electromagnetic radiation. All cords and cables should be less than 3m in length.

MAINTENANCE

REGULAR MAINTENANCE

This instrument does not require any regular maintenance.

CLEANING

If desired, the interior of the instrument may be cleaned using compressed air to dislodge any accumulated dust. (See the “TOP COVER REMOVAL” section for instructions on accessing the interior.) No other cleaning is recommended.

PERFORMANCE CHECK SHEET