

- Linear rise to ± 1 , ± 1.5 , or -2 kV
- Adjustable transition times
- Includes IEEE-488.2 GPIB, RS-232

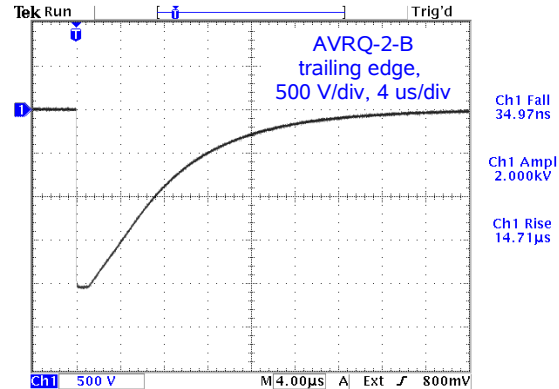

- Ideal for slew rate testing of optocouplers & optoisolators
- Ideal for high-voltage sweep applications

Models AVRQ-2-B and AVRQ-3-B are suitable for generating the high-speed, high-voltage waveforms necessary for transient immunity testing of opto-couplers and other semiconductor devices. The AVRQ series is also suitable for a range of other applications requiring a high-voltage “sweep” waveform, such as sweep-control of particle beam systems.

The AVRQ-2-B generates a fixed-amplitude -2 kV pulse with a linear leading edge, followed by a slower exponential decay back to zero. The transition time (10%-90%) of the leading edge is variable from 50 ns to 500 ns. The high-voltage pulse is provided on a rear-panel SHV connector. The load connected to this output should have a high DC resistance (> 10 M Ω), and a capacitance of approximately 40 pF (including the capacitance of any cabling).

The AVRQ-3-B offers four selectable amplitudes (-1.5 kV, -1 kV, $+1$ kV and $+1.5$ kV), with the transition time (10%-90%) of the leading edge variable from less than 25 ns to more than 250 ns. Rather than connecting a load using a rear-panel connector, the AVRQ-3-B provides a ZIF socket for standard 8-pin single and dual channel opto-couplers. The high-voltage pulse is applied across the input and output sides of the opto-coupler, with the outside side being ground-referenced, and the input side floating on the high-voltage pulse. The AVRQ-3-B also provides a floating current source to bias the input LED (0 mA, or $1-16$ mA adjustable) and a DC power supply adjustable from $+3.0$ V to $+5.0$ V to power the output-side VCC pin. A variable pull-up resistance is provided on the logic output of the DUT, variable from 300 Ohms to 5 kilohms. The high-voltage pulse and the opto-coupler logic output are accessible for measurement with high-impedance probes on rear-panel connectors.

Other output connector arrangements or device sockets can be provided for the AVRQ-2-B and AVRQ-3-B, upon request.

For both models, the high voltage pulse starts to decay back to

zero approximately 1 microsecond after the start of the leading transition,. The fall time of this decay is at least ten times greater than the rise time of the leading edge. The pulse repetition frequency is adjustable from 1 Hz to 10 Hz, using the front panel controls or by computer command. This instrument may also be triggered by an external TTL trigger pulse (10 Hz maximum), by a computer command, or by a front-panel pushbutton.

On both models, the output will “time-out” after 90 seconds of command inactivity. After that time, the output will be disabled. The output must be re-enabled from the front panel or by computer command for the next test.

A delay control and a sync output are provided for oscilloscope triggering purposes. The sync output (a BNC connector located on front panel) provides a TTL pulse with 100 ns pulse width, and will drive 50 Ohms. The delay between the main output and the sync output is variable from 0 to 1.0 seconds.

These models require a high-impedance load. They will not operate correctly into lower resistances, or into loads with more than the rated capacitance (including the cabling and oscilloscope probe capacitance). The rise time is NOT a calibrated value due to the influence of the load capacitance – it must be measured with an appropriate high-voltage oscilloscope probe system.

Both models include a complete computer control interface (see <http://www.avtechpulse.com/gpib> for details). This provides GPIB and RS-232 computer-control, as well as front panel keypad and adjust knob control of the output pulse parameters. A large back-lit LCD displays the output amplitude, frequency, pulse width, and delay. To allow easy integration into automated test systems, the programming command set is based on the SCPI standard, and LabView drivers are available for download at the Avtech web site (<http://www.avtechpulse.com/labview>).



AVRQ-2-B



SPECIFICATIONS

AVRQ SERIES

Model:	AVRQ-2-B ¹	AVRQ-3-B ¹
High-Voltage Pulse Amplitude:	-2 kV, fixed, +/- 5%	-1.5, -1, +1, or +1.5 kV, selectable. +/- 5%.
Load resistance:	> 10 Megohms (this is not a 50 Ohm system.)	
Load capacitance:	≈ 40 pF total, including DUT capacitance, cabling ⁵ and probes.	≈ 15 pF total, including DUT capacitance and probes.
Load connection style:	Connect to your load using a short length (0 - 30 cm) of user-supplied coaxial cabling connected to the rear-panel output connector.	A zero-insertion-force (ZIF) socket is provided for standard 8-pin single and dual-channel opto- couplers. The socket is accessed through a rear- panel door. See pinout details below.
Leading edge rise time ² : (10% - 90%):	< 50 ns to > 500 ns, variable.	< 25 ns to > 250 ns, variable.
Leading edge shape:	Linear, approximately. See the typical waveform photos on the preceding and following pages.	
Trailing edge fall time ³ : (90% - 10%):	At least ten times greater than the leading edge rise time. Not adjustable.	
Trailing edge shape:	Exponential decay, approximately. See the typical waveform photos on the preceding and following pages.	
Pulse width:	1 us (measured between the start of the leading edge and the start of the falling edge). Approximate. Not adjustable.	
PRF:	Internal trigger: 1 to 10 Hz External trigger: 0 to 10 Hz	
LED bias current, floating:	N/A	0 mA, or +1 to +16 mA, adjustable
VCC power supply:	N/A	+3.0V to +5.0V, adjustable
Logic output pull-up resistance:	N/A	300 Ω to 5 kΩ, adjustable
Output connector, HV PULSE:	SHV female	BNC female, suitable for use with the Tektronix P5100 high-voltage probe and 013-0291-00 probe-tip-to-BNC adapter
Output connector, logic output:	N/A	BNC female, and a two-pin header suitable for use with the Tektronix P6246 differential probe. The two outputs are wired in parallel internally.
Output enable timer:	The output will only remain active for 90 seconds after the last output parameter update. After that time, the output will be disabled. The output must be re-enabled from the front panel or by computer command for the next test sequence.	
Propagation delay:	≤ 200 ns (Ext trig in to start of output pulse)	
Jitter (Ext trig in to pulse out):	± 200 ps ± 0.03% of sync delay	
Trigger required (ext trig mode):	TTL levels (0 and +3V to +5V), 50 ns or wider	
Sync delay:	Variable 0 to ± 1.0 seconds	
Sync output:	TTL levels (0 and +3V to +5V), 100 ns, will drive 50 Ohm loads	
Gate input:	Synchronous, active high or low, switchable. Suppresses triggering when active.	
Connectors:	Out: SHV (rear-panel). Trig, Sync, Gate: BNC (rear-panel)	
GPIB and RS-232 control:	Yes. (Visit http://www.avtechpulse.com/labview for LabView drivers.)	
Telnet / Web control:	Optional ⁴ . See http://www.avtechpulse.com/options/tnt for details.	
Power requirements:	100 - 240 Volts, 50 - 60 Hz	
Dimensions: (H x W x D)	100 mm x 430 mm x 475 mm (3.9" x 17" x 18.8")	145 mm x 430 mm x 475 mm (5.7" x 17" x 18.8")
Chassis material:	cast aluminum frame and handles, blue vinyl on aluminum cover plates	
Temperature range:	+5°C to +40°C	

- 1) -B suffix indicates IEEE-488.2 GPIB and RS-232 control of amplitude, pulse width, PRF and delay (See <http://www.avtechpulse.com/gpib/>).
- 2) The rise time is affected by the load capacitance. A high-voltage high-bandwidth oscilloscope probe such as the Tektronix P5100 should always be used to verify the actual output rise time, rather than relying on the programmed value.
- 3) Refers to the trailing edge, which swings from -1000V or -2000V to 0V
- 4) Add the suffix -TNT to the model number to specify the Telnet / Web control option.
- 5) Note that coaxial cabling typically adds 30 pF/ft.

Use the "Pick the Perfect Pulser" parametric search engine
at <http://www.avtechpulse.com/pick>
to find the best pulser for your application!

STANDARD ZIF SOCKET FOR THE AVRQ-3-B

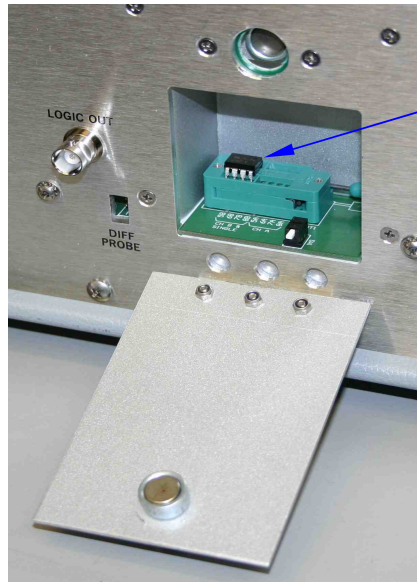
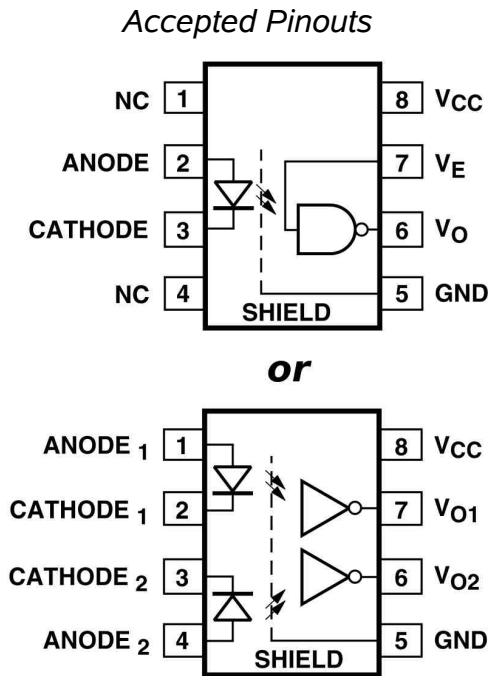

An opto-coupler installed in the ZIF socket. The door must be closed before the output

BASIC TEST ARRANGEMENT FOR THE AVRQ-3-B

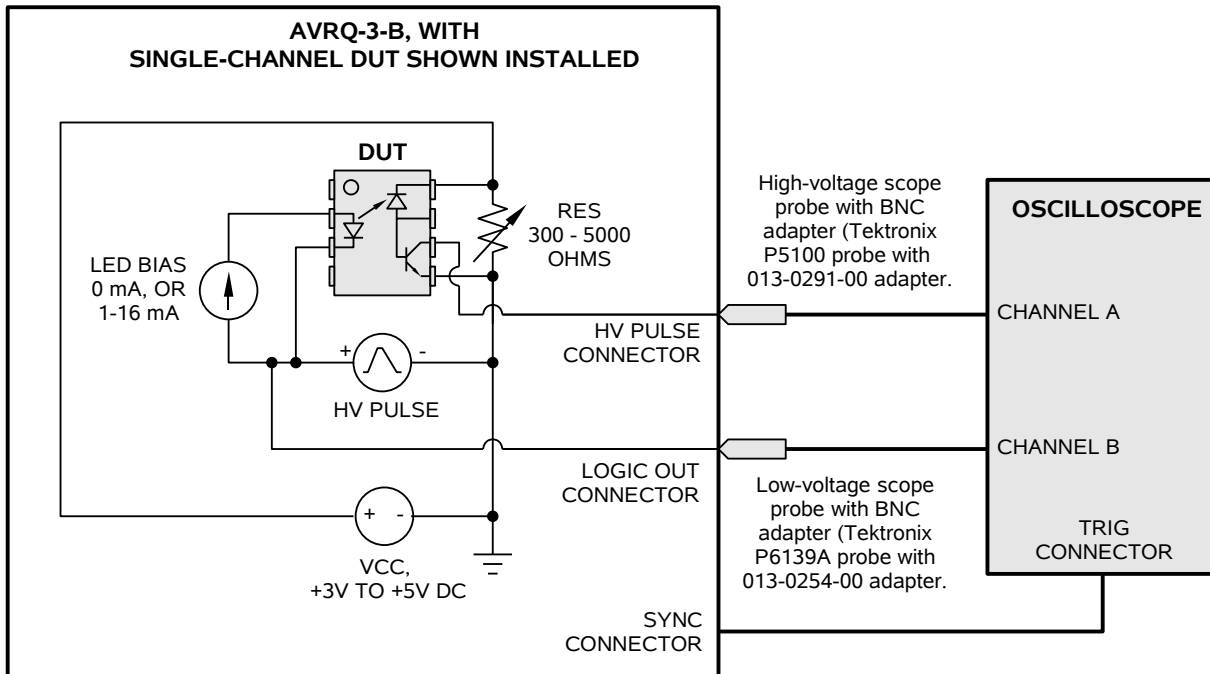

TYPICAL WAVEFORMS FOR THE AVRQ-3-B

Testing CH A of an Avago HCPL-2630 dual-channel opto-coupler, with a -1 kV pulse, $V_{CC} = +5V$, LED bias = +7.5 mA, and a pull-up resistance of 350 Ohms shows that a logic glitch starts to occur when the HV pulse transition time is 70.69 ns. The glitch increases in amplitude as the rise time decreases:

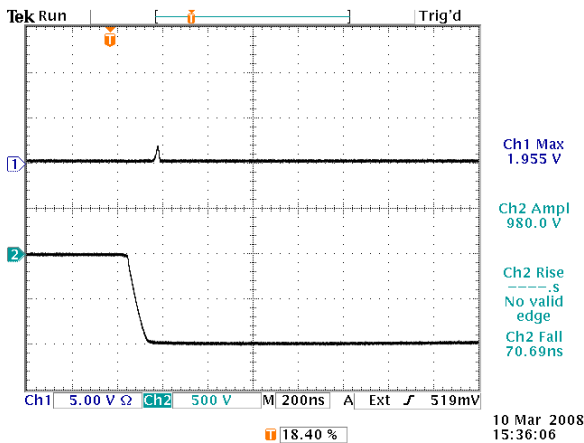

Top: HCPL-2630 logic output, 5V/div, 200 ns/div.
Bottom: -1 kV pulse with 70.69 ns transition time applied across the HCPL-2630 input/output sides.

The logic glitch is just starting. The estimated CMTI under these conditions is thus $1 \text{ kV} / (0.9-0.1) / 70.69 \text{ ns} = 17.7 \text{ kV/us}$. The manufacturer's specification is 5 kV/us.

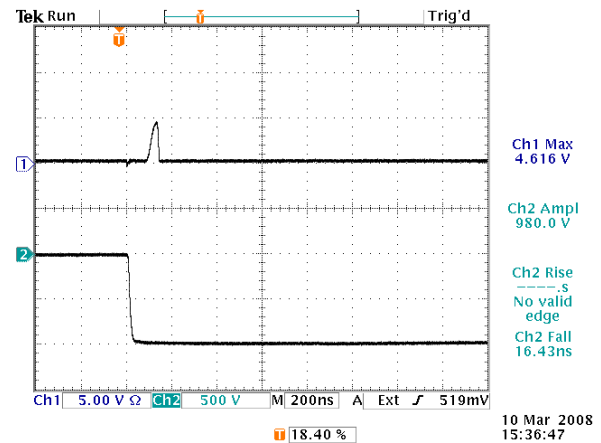

Top: HCPL-2630 logic output, 5V/div, 200 ns/div.
Bottom: -1 kV pulse with 16.43 ns transition time applied across the HCPL-2630 input/output sides.

The logic glitch has increased with the decreased HV pulse transition time.

Testing HCPL-2601 single-channel opto-couplers from two different manufacturers with a +1 kV pulse, $V_{CC} = +5V$, LED bias = 0 mA, and a pull-up resistance of 350 Ohms shows a difference in performance:

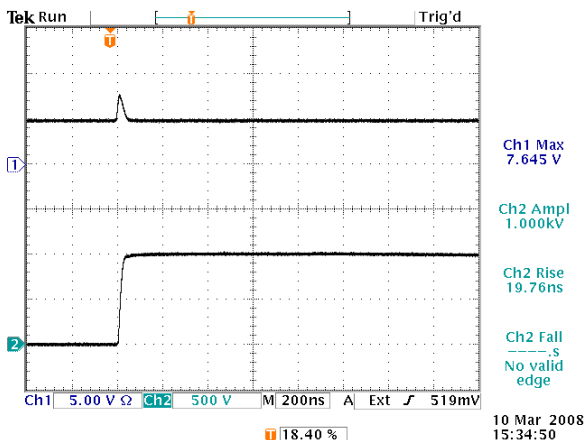

Top: Avago HCPL-2601 logic output, 5V/div.
Bottom: +1 kV pulse with 19.76 ns transition time applied across the HCPL-2601 input/output sides.

Some of the HV pulse capacitively couples to the logic output, causing a positive spike, but the logic state does not change. No glitch is observed. The CMTI thus exceeds $1 \text{ kV} / (0.9-0.1) / 19.76 \text{ ns} = 63.2 \text{ kV/us}$, which is the limit of this test system.

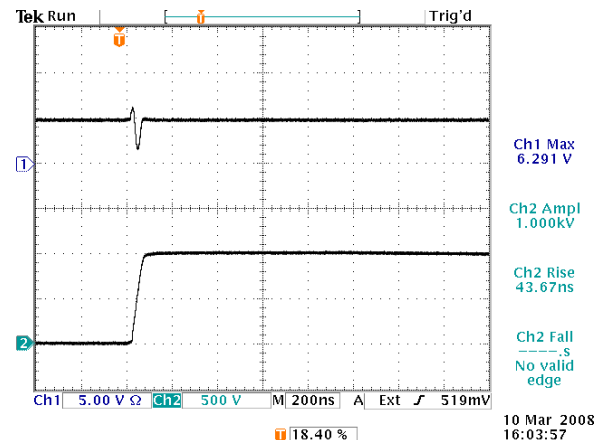

Top: QTC HCPL-2601 logic output, 5V/div.
Bottom: +1 kV pulse with 43.67 ns transition time applied across the HCPL-2601 input/output sides.

With this device, a negative-going glitch is observed. (It is not caused by capacitive coupling, since it is opposite in polarity to the HV pulse slope.) The observed CMTI is thus $1 \text{ kV} / (0.9-0.1) / 43.67 \text{ ns} = 28.6 \text{ kV/us}$.