



AVO-8 Mainframe (Output connectors are on rear panel)

The AVO-8 series of pulse generators is designed for pulsing laser diodes and other low impedance loads with rectangular pulses as high as 500 Amperes (or 50 Volts), pulse widths from 2 us to DC, and average output powers to several kilowatts.

Each AVO-8 model essentially acts as a high-current, high-speed switch for the output of a user-supplied DC power supply. The AVO-8 is installed between the DC power supply and the load. The signal timing is controlled by the AVO-8, and the amplitude (output voltage) is controlled by the DC power supply. Avtech can recommend suitable DC power supplies for particular applications, if you do not already have one.

Each model consists of a single "3U" high (5.25") rack-mountable (19" wide) instrument mainframe.

On all models, the output pulse amplitude (voltage) is controlled by the user-supplied high-current DC lab power supply that is connected to the AVO-8 instrument (see the diagram on the following pages). The AVO-8 instrument acts as a high-efficiency, high-speed switch that connects the DC lab power supply to the load during the output pulse duration. The output is shorted to ground between pulses. The output pulse voltage amplitude is approximately equal to the lab power supply voltage minus 2V. The lab power supply must be capable of supplying at least the average value (I_{AVG}) of the peak current supplied to the load (I_{OUT}). I_{AVG} , I_{OUT} , pulse width (PW) and frequency are related as shown in the diagram on the following pages. Protective circuits monitor the lab power supply voltage level and the output circuit temperature and will automatically disable the triggering of the output stage if either the applied voltage or temperature exceed rated values.

The AVO-8 instruments are voltage pulsers. A non-inductive resistor must be connected in series with the diode under test to limit the current to the maximum rated current (or less). See the diagram on the following pages for details. For some applications, the Avtech AV-HTL series of high-power, ultra-low-inductance resistors may be suitable (e.g., the Avtech AV-HTL-0R2-HLZ, described at <http://www.avtechpulse.com/accessories/av-htl-0r2>, is suitable for most AVO-8C3-B applications).

Model AVO-8A3-B provides a peak output current of 50A to a load impedance as low as 1 Ohm and requires a 52V external DC power supply. The AVO-8A3-B can operate at duty cycles up to 80% in pulse mode, and 100% in DC mode.

Model AVO-8C3-B provides up to 200A to a load impedance as low as 0.2 Ohms and requires a 42V DC power supply. The AVO-8C3-B can operate at duty cycles up to 100% for currents of up to 100A, and 50% for higher peak currents.

Model AVO-8D3-B is similar to the AVO-8C3-B, except that it operates up to 500A. It can operate at duty cycles to 35% at 200A to 250A, and 7% at 250A to 500A.

For high duty cycle (> 50%) or wide pulse width (> 1 ms) applications the current rating of the lab power supply should be near the desired peak output load current, particularly if low output pulse droop is required. However, for low duty cycle applications (e.g. 10%) the current rating of the lab power supply may be

- ◆ IEEE-488.2 GPIB and RS-232 control (-B units)
- ◆ Peak outputs to 500 Amperes
- ◆ Pulse widths from 2 us to DC
- ◆ Microsecond-scale rise times

considerably less than the desired peak load current because the large capacitance present in the AVO-8 output circuits (170000 uF typically) provides the necessary high peak pulse current.

The pulse repetition frequency is variable for all models from 1 Hz to 1 kHz using the internal oscillator. A delay control and a sync output are provided for oscilloscope triggering purposes. A pushbutton is provided for one-shot operation. The units can also be triggered externally using a TTL-level pulse. All AVO-8 units include a monitor output option that provides an attenuated coincident replica of the main output current pulse.

The output pulse width may be set to track the input trigger pulse width over the range of 2.0 us to DC. The output duty cycle may be as high as 100% provided the average current does not exceed 100 Amperes (50 Amps for the AVO-8A3-B).

All models offer an optional current limit feature. This function will disable the output if the current exceeds a set level. The response time of the limit circuit is < 5 us. The trip level may be set from the front panel or by computer command. If the limit circuit is tripped the user must re-enable the output from the front panel or by computer command.

The output signal is provided on a high-voltage, high-current rear-panel safety connector. Users can connect to their series resistances and/or loads using one of two methods:

1. They may use the optional -AK9 accessory kit, which provides a 1 meter long cable and an adapter for the load end. The adapter also provides four contact posts (two identical posts for the signal, and two for the ground), to which the load may be attached using M6x1 threaded screws (maximum depth of 15 mm). The adapter may be plugged into the cable, and the cable into the rear panel. Alternatively, the adapter may be plugged directly into the rear panel.
2. They may use the Avtech AV-HTL-xxx-HLZ series of resistors (where xxx is 0R1, 0R2, or 1R0, depending on the required resistance). These resistors include a 1 meter long cable that mates to the output connector on the AVO-8. These resistors are designed so that the user may mount a laser diode in series with them.

IEEE-488.2 GPIB and RS-232 control of pulse width, pulse repetition frequency, and delay is provided. These models include a front-panel keypad and adjust knob control of the output pulse parameters, along with a four line 40-character back-lit LCD display of the pulse width, pulse repetition frequency and delay. (Note that the DC power supply must be equipped with a GPIB feature, if you wish to remotely control the amplitude.) Optional telnet or web-based remote control is also available (<http://www.avtechpulse.com/options/tnt>), for control over local area networks or the internet.

Visit the application note area of the Avtech web site (<http://www.avtechpulse.com/appnote>) for general applications assistance.



SPECIFICATIONS

AVO-8 SERIES

Model ¹ :	AVO-8A3-B	AVO-8C3-B	AVO-8D3-B
Amplitude, voltage: (controlled by the DC power supply)	0 to 50 Volts	0 to 40 Volts	0 to 50 Volts
Maximum output current: (for all output voltages)	50 Amps	200 Amps	500 Amps
Typical minimum load impedance ¹¹ : (required to limit output current)	1 Ω	0.2 Ω	0.1 Ω
Pulse width (FWHM):	2 us to 1 second, and DC ⁵ .		5 us to 10 ms
Pulse repetition freq. (PRF):	1 Hz to 1 kHz		
Rise and fall times (20%-80%) ⁹ :	≤ 0.5 us	≤ 1 us	≤ 2 us
Maximum duty cycle, pulse mode:	0 to 50A: 80% ¹⁴	0 to 100A: 80% ¹⁴ 100A to 200A: 50%	0 to 100A: 80% ¹⁴ 100A to 200A: 50% 200A to 250A: 35% 250A to 500A: 7%
DC mode:	Yes	Yes, up to 100 A	Yes, up to 100 A
Output impedance:	≤ .025 Ohms	≤ 0.01 Ohms	
Polarity ² :	Positive or negative (specify)		
Current limit function:	Optional ¹⁰ . Will disable the output if the current exceeds a set level. The trip level may be set from the front panel, or by computer command. Requires user intervention to re-enable the output. Trip level accuracy: ±2% ± 2A. Response time: < 5 us.		
GPIB and RS-232 control ¹ :	GPIB and RS-232 ports are standard on -B units.		
LabView drivers:	Check http://www.avtechpulse.com/labview for availability and downloads		
Internet control ³ :	Optional on -B units. See http://www.avtechpulse.com/options/tnt for details.		
Propagation delay:	± 100 ns (Ext trig in to pulse out)		
Jitter:	± 500 ps ± 0.03% of sync delay (Ext trig in to pulse out)		
Trigger required, for external trigger modes:	External trigger, internal PW control mode: +5 Volt, 50 ns or wider (TTL) External trigger, external PW control mode: +5 Volt, PW _{IN} = PW _{OUT} (TTL)		
Monitor output:	Provides an attenuated coincident replica of the main output current pulse		
Sync delay, Sync output:	Sync out to pulse out: Variable 0 to ± 1 second. + 3 Volts, 100 ns, will drive 50 Ohm loads		
Gate input:	Synchronous or asynchronous, active high or low, switchable. Suppresses triggering when active.		
Connectors (DC Power in):	6 mm plug / 4 mm sockets ⁶ (+ red, - black)		
Connectors (Output):	Positronic (www.positronic.com) female connector ¹²		
Output cabling:	User-supplied, or use optional -AK9 accessory kit (described below).		
Optional recommended accessory kits ⁴ :	<p>-AK3 option: Provides two 1 m cables (1 red, 1 black) with 6mm safety sockets⁸, and two 6mm safety plug to M6 stud adapters⁷. Recommended for connecting AVO-8 units to the DC power supply.</p> <p>-AK9 option: Provides one AV-HLZ1-100 cable (100 cm length, Z₀ = 1 Ohm. This transmission line cable matches low impedance loads without degrading the signal rise and fall times significantly. The chassis end of the cable is terminated with a Positronic male connector¹³ and the load end is terminated with a Positronic female connector¹²). Also provides an adapter⁷ which mates to the end of this cable, and provides the output on two identical contact posts into which M6x1 threaded screws may be screwed to a maximum depth of 15 mm. This cable is not required to connect to the AV-HTL-xxx-HLZ series resistors – these resistors (ordered separately) include their own cabling.</p>		
Suggested series resistor:	Avtech AV-HTL-1R0-HLZ	Avtech AV-HTL-0R2-HLZ	Avtech AV-HTL-0R1-HLZ
Power requirements:	DC ⁴ : 0 to 52 V, > 50 Amp	0 to 42 V, > 100 Amp	0 to 52 V, > 90 Amp
	AC:	100 - 240 Volts, 50 - 60 Hz	
Cooling:	Self-contained fan.		
Dimensions:	138 mm x 430 mm x 425 mm, 5.5" x 17" x 16.8"		
Rack-mount kit:	Add the suffix -R6 to the model number to include 19" rack mount kit.		
Chassis material:	Anodized aluminum, with blue plastic trim		
Temperature range:	+5°C to +40°C		

- 1) -B suffix indicates IEEE-488.2 GPIB and RS-232 control of pulse width, PRF and delay. (See <http://www.avtechpulse.com/gpib> for details).
- 2) Indicate desired polarity by suffixing the model number with -P or -N (i.e. positive or negative).
- 3) Add the suffix -TNT to the model number to specify the Internet control (Telnet and Web) option.
- 4) Requires a user-supplied DC power supply. Avtech suggests Xantrex as a source of DC power supplies (<http://www.xantrex.com>). Contact Avtech for recommendations about DC power supplies appropriate for your application. The cables for connecting the external DC power supply are not included with the standard model. 6 mm plug to 6 mm plug cables are available in the optional -AK3 accessory kit. These may or may not be suitable for your power supply, depending on the power supply's connectors. It is possible to cut and strip the ends of the optional accessory cables, and to attach other terminations. Multi-Contact (<http://www.multi-contact.com> or <http://www.multi-contact-usa.com>) can supply 6 mm plug to cable lug cables, and other configurations.
- 5) When externally triggered, the output pulse width can be controlled by the front panel controls (or computer command), or it can be set to follow the input pulse width (i.e., PW_{IN}=PW_{OUT} mode).
- 6) Multi-Contact (<http://www.multi-contact.com> or <http://www.multi-contact-usa.com>) ID/S6AR-N-B4S series, or similar.
- 7) Multi-Contact (<http://www.multi-contact.com> or <http://www.multi-contact-usa.com>) SLK616-AR/BGG series, or similar.
- 8) Add the suffix(es) -AK3 and/or -AK9 as appropriate, to the model number to include the accessory kit(s).
- 9) Valid for non-inductive loads installed directly on the output connectors (i.e., zero cable length) using low-inductance adapters, or for loads installed directly on the end of a AV-HLZ1-100 cable plugged into the output connector. Inductive loads or cables will degrade the rise times.
- 10) Add the suffix -TRIP to the model number to specify the current limit function. Units without this option will still have an over-current protection feature, but the trip level will be non-adjustable and set 20% above the maximum rated current, approximately.
- 11) The load impedance can be reduced below these values, as long as the maximum current rating is observed. Most diode loads will require some series resistance to be added to limit the current.
- 12) Positronic part number GG8888F1, with four GGFIT00MS/AA high-current contacts. The inner two contacts carry the signal, and the outer two carry the ground lines.
- 13) Positronic part number GG8888M1, with four GGMIT00MS/AA high-current contacts. The inner two contacts carry the signal, and the outer two carry the ground lines.
- 14) Up to 100%, if externally triggered and the PW_{IN} = PW_{OUT} mode is enabled.



Pulser mainframe (left) with AV-HLZ1-100 output cable (middle) and mating adapter (right)



Mainframe Rear Panel

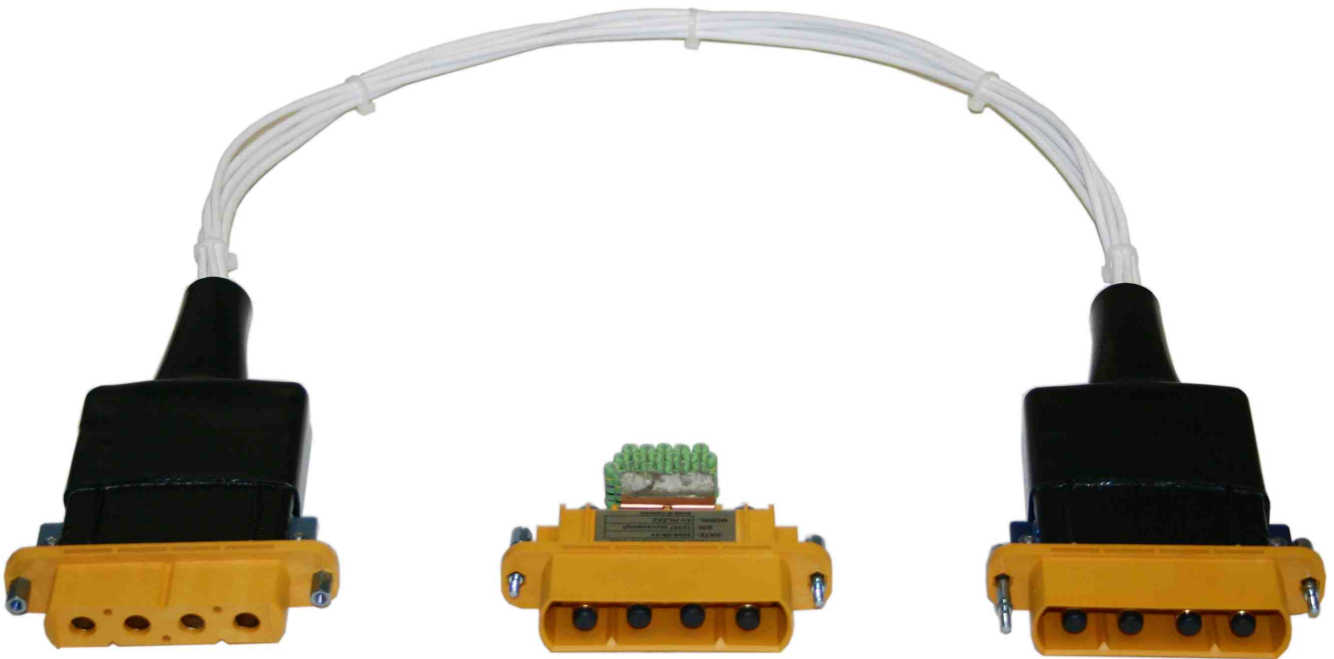

*AV-HLZ1-100 output cable (right and left) and mating adapter (middle).
The adapter is shown with some test resistors installed on copper brackets.
The copper brackets are screwed into the four contact posts on the rear of the
adapter. These brackets and resistors are not included with the adapter;
this is just a sample configuration.*

Basic Connection Arrangement

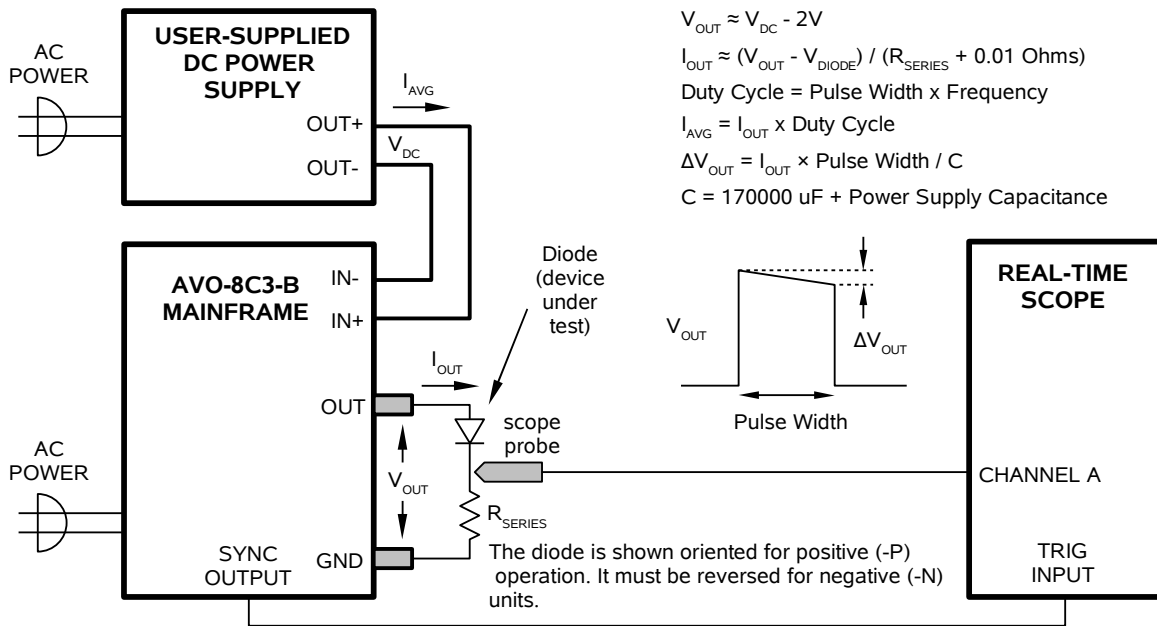

Typical Output Waveforms

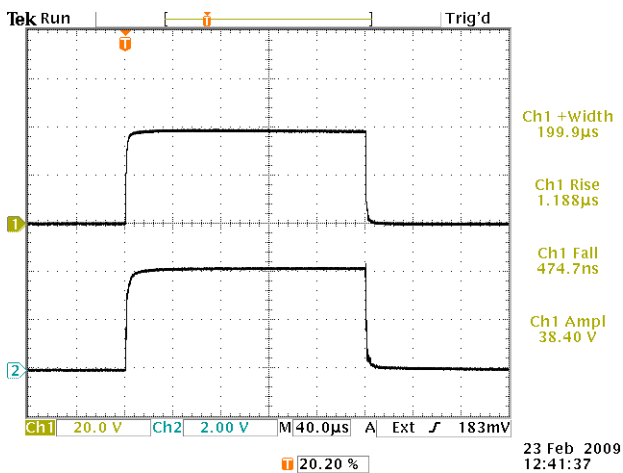

Rise Time Test at 400A.

Top: OUT, +38V into AV-HTL-0R1 test load (0.097Ω, ≈ 400A), 200 us pulse width.

Bottom: Monitor output, into open circuit.

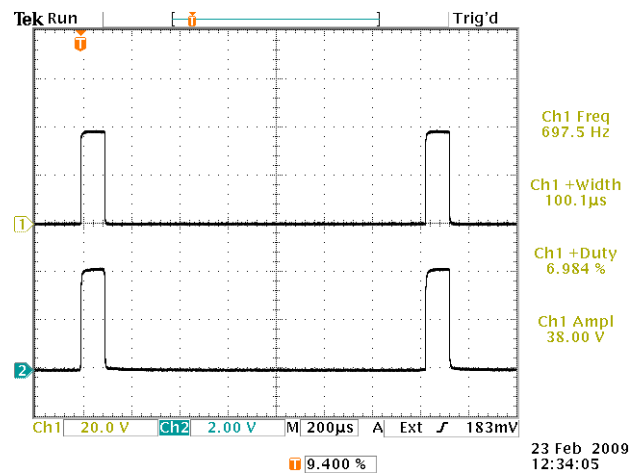

High Duty Cycle Test at 400A

Top: OUT, +38V into AV-HTL-0R1 test load (0.097Ω, ≈ 400A), 7% duty cycle.

Bottom: Monitor output, into open circuit.

Contact Avtech (info@avtechpulse.com) with your special requirement!

Avtech regularly adapts standard models for special and "one-of-a-kind" applications.