

- ◆ Amplitudes to 500, 700, or 1000 Volts
- ◆ 20, 30, or 50 ns rise and fall times
- ◆ Pulse widths variable from 0.1-100 us, or 0.2-200 us
- ◆ PRF to 1 kHz or 10 kHz
- ◆ Peak power output to 20 kW
- ◆ For time-of-flight and many other applications
- ◆ IEEE-488.2 GPIB and RS-232 interfaces

The AVR-5B, AVR-7B, and AVR-8A series of pulse generators are fast high-voltage pulse generators capable of driving load impedances of 50Ω and higher. These easy-to-use models are suitable for many different test applications, including resistor and attenuator testing, semiconductor and laser diode characterization, time-of-flight applications, and many other applications.

Model AVR-5B-B provides up to 500V out (to 50Ω) with rise times of 20 ns and pulse widths variable from 100 ns to 100 us. The pulse repetition frequency (or "PRF") is variable from 1 Hz to 10 kHz. This model will provide peak output power of 5000 Watts and average outputs of 50 Watts (i.e. 1% maximum duty cycle). The standard output connector is N-type.

Model AVR-7B-B is similar, but provides up to 700V (to 50Ω) with rise times of 30 ns. This model will provide peak output power of 10000 Watts and average outputs of 50 Watts (i.e. 0.5% maximum duty cycle).

The extra-high-voltage model AVR-8A-B provides up to 1000V out (to 50Ω) with rise times of 50 ns and pulse widths variable from 200 ns to 200 us. PRF is variable from 1 Hz to 1 kHz. This model will provide peak output power of 20000 Watts and average outputs of 40 Watts (i.e. 0.2% maximum duty cycle). The standard output connector is SHV-type.

The output stages in all models will safely withstand any combination of front panel control settings, output open or short circuits, and high-duty cycles. An internal power supply monitor removes the power to the output stage for five seconds if an average power overload exists. The outputs will source up to 12, 16, or 23 Amps (for models AVR-5B-B, AVR-7B-B, and AVR-8A-B, respectively) and will automatically shut down if the load current exceeds this rated current.

Aside from the internal clock, all models can also be triggered by a single-pulse pushbutton or an external TTL-level trigger input. When triggered externally, the output pulse width can be set to track the input trigger pulse width ($PW_{OUT} = PW_{IN}$). A delay control and a sync output are provided for oscilloscope triggering. A gate input is also provided. Either output polarity can be provided, as well as a dual output polarity option.

All models include a computer control interface (see <http://www.avtechpulse.com/gpiib> for details). This provides GPIB and RS-232 computer-control, as well as front panel keypad and adjust knob control of the output pulse parameters. A large back-lit

LCD displays the output amplitude, polarity, frequency, pulse width, and delay. To allow easy integration into automated test systems, the programming command set is based on the SCPI standard, and LabView drivers are available for download at <http://www.avtechpulse.com/labview>. An Ethernet port for Telnet or web-based control is optional (-TNT option, for details see <http://www.avtechpulse.com/options/tnt>).

All models are available with optional electronic analog control of the amplitude (the "-EA" option). With this feature, the output amplitude may be controlled by an externally applied analog DC voltage (0 to +10 V).

The standard output connectors may optionally be changed from N (on the AVR-5 and AVR-7 series) or SHV (AVR-8) to SHV, MHV or HN by adding "-SHV", "-MHV", or "-HN" to the model number. All models require 100 - 240 V, 50 - 60 Hz, and are mounted in a rugged all-metal 3.9" x 17" x 14.8" chassis.

A burst mode option is also available, allowing a burst of 1-500 pulses to be generated in response to a single trigger event. See <http://www.avtechpulse.com/options/br> for details.

The maximum pulse widths and duty cycles of these instruments may be extended if the intended load is high-impedance (i.e., much greater than 50Ω, such as a plate load). Contact the factory with your special requirements. A parametric search engine is available online at <http://www.avtechpulse.com/pick> to assist you in selecting the best instrument for your application.

For applications requiring high-voltage pulses with faster rise times, see the AVRZ-5 series (datasheets & pricing are available at <http://www.avtechpulse.com/speed>), which offers 0 to 500V pulses with 9 ns rise times, and pulse widths as low as 15 ns or as high as 10 us. See also the AVR-F Series at <http://www.avtechpulse.com/medium/avr-f-7a> for 600 Volt and 750 Volt units with 6 and 7.5 ns rise times.

Models in the AVR series may be suitable for replacing obsolete models from the former Velonex Corporation in many applications.

Actual test waveforms from shipped units are available from the online data pages for each model, at:

- <http://www.avtechpulse.com/medium/avr-5b/#testresults>
- <http://www.avtechpulse.com/medium/avr-7b/#testresults>
- <http://www.avtechpulse.com/medium/avr-8a/#testresults>



AVR-5B-B

Model ¹ :	AVR-5B-B	AVR-7B-B	AVR-8A-B
Amplitude: ($R_L \geq 50\Omega$) ^{2,3} :	0 to 500 Volts	0 to 700 Volts	0 to 1000 Volts
Output impedance:	2 Ω , approximately		
Rise & fall times (20%-80%):	≤ 20 ns	≤ 30 ns	≤ 50 ns
Pulse width (FWHM) ⁴ :	100 ns to 100 μ s		200 ns to 200 μ s
PRF: external trigger mode:	0 to 10 kHz		0 to 1 kHz
internal trigger:	1 Hz to 10 kHz		1 Hz to 1 kHz
Duty cycle (max):	1%	0.5%	0.2%
Average power out (max):	50 Watts		40 Watts
Max. droop at max. pulse width:	4%		6%
Polarity ⁵ :	Positive or negative or both (specify -P, -N, or -PN)		
GPIB and RS-232 control ² :	Standard on -B units. See http://www.avtechpulse.com/gpib for more information.		
LabView Drivers:	Available at http://www.avtechpulse.com/labview .		
Internet control (Telnet & Web):	Optional ⁶ . See http://www.avtechpulse.com/options/tnt for details.		
Burst mode:	Optional ¹¹ . Generates 1-500 pulses per trigger event. See http://www.avtechpulse.com/options/br .		
Propagation delay:	≤ 200 ns (Ext trig in to pulse out)		
Jitter (Ext trig in to pulse out):	± 100 ps $\pm 0.03\%$ of sync delay		
Trigger required, Ext Trig mode:	Mode A: +5 Volt, 50 ns or wider (TTL) Mode B: +5 Volt, $PW_{IN} = PW_{OUT}$ (TTL)		
Sync delay:	Variable 0 to ± 100 μ s (sync out to pulse out)		
Sync output:	+3 Volts, 100 ns, will drive 50 Ohm loads		
Gated operation:	Synchronous or asynchronous, active high or low, switchable. Suppresses triggering when active.		
Connectors:	OUT: N ^{7,8} Trig, Sync, Gate: BNC		OUT: SHV ^{9,10} Trig, Sync, Gate: BNC
Power requirements:	100 - 240 Volts, 50 - 60 Hz		
Dimensions (H x W x D):	100 mm x 430 mm x 375 mm (3.9" x 17" x 14.8")		
Chassis material:	cast aluminum frame and handles, blue vinyl on aluminum cover plates		
Mounting:	Any		
Temperature range:	+5°C to +40°C		

- B suffix indicates GPIB-equipped model.
- For analog electronic control (0 to +10V) of amplitude, add the suffix -EA to the model number. Electronic control units also include the standard front panel controls.
- For operation at amplitudes of less than 10% of full-scale, best results will be obtained by setting the amplitude near full-scale and using external attenuators on the output.
- The output pulse width may also be controlled externally by applying a TTL-level trigger of the desired width to a rear-panel BNC connector ($PW_{IN} = PW_{OUT}$ mode).
- Indicate desired polarity by suffixing the model number with -P or -N (i.e. positive or negative) or -PN for dual polarity option.
- Add the suffix -TNT to the model number to specify the internet control

- option.
- SHV, MHV or HN output connectors can also be provided. To specify, suffix the model number with -SHV, -MHV or -HN as required.
- An N-male to BNC-female adapter (Amphenol P/N 31-216) is available. Add the suffix -ADPT2 to the model number to order this adapter.
- An adapter kit, consisting of an SHV PLUG to MHV FEMALE adapter and an MHV MALE to BNC FEMALE adapter, is available. Add the suffix -ADPT1 to the model number to order this kit.
- MHV, N or HN output connectors can also be provided. To specify, suffix the model number with -MHV, -NC or -HN as required.
- Add the suffix -BR to the model number to specify the burst mode option. See <http://www.avtechpulse.com/options/br> for details about this option.

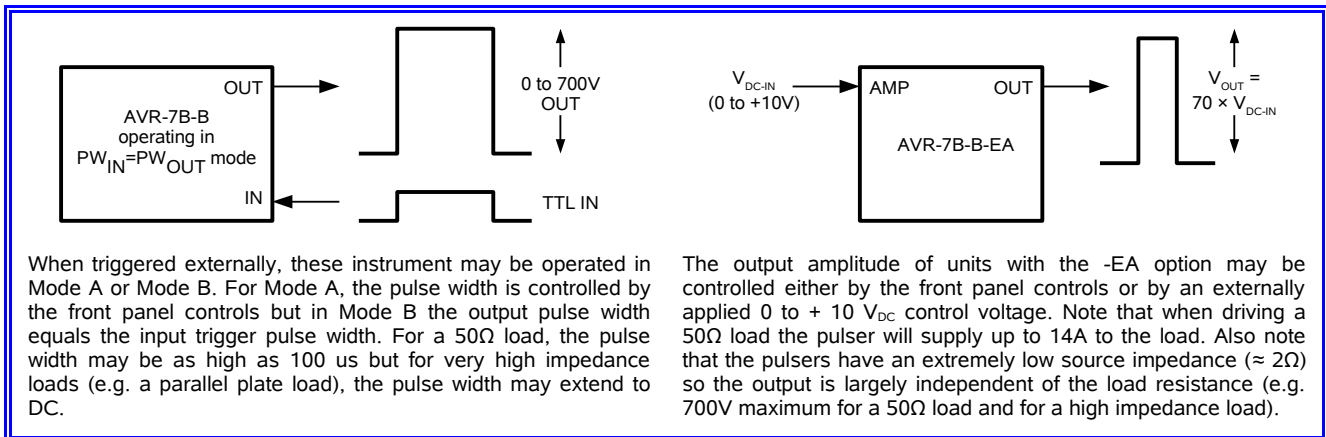

Use the "Pick the Perfect Pulser" parametric search engine at <http://www.avtechpulse.com/pick> to find the best pulser for your application!