



AVP-AV-1S-C

- ◆ Rise times as fast as 80 ps
- ◆ Amplitudes to 40 Volts
- ◆ PRF to 1 MHz
- ◆ Pulse widths from 0.2 to 500 ns
- ◆ IEEE-488.2 GPIB and RS-232 control (-B units)
- ◆ Ethernet/VXI port (-B units)

The AVP series of pulse generators offer the fastest rise times available in the Avtech product line, with 20%-80% rise times as low as 80 ps.

The AVP-AV-1S-C model provides amplitudes of up to 5V, with 80 ps rise times and 200 ps fall times. The pulse width is adjustable from 200 ps to 4 ns. The maximum pulse repetition frequency (PRF) is 1 MHz. This model is not available with computer control functionality. The remaining models below (with the “-B” suffix) do offer computer control functions.

The AVP-AV-1-B provides amplitudes up to 10V, pulse widths of 0.4 to 4 ns, and 120 ps rise times.

The AVP-AV-HV2-B provides amplitudes up to 20V, pulse widths of 0.3 to 2 ns (optionally 4 ns), and 120 ps rise times.

The high-voltage AVP-AV-HV3-B operates to 40V, with pulse widths variable from 0.4 to 2 ns (optionally 4 ns), and 150 ps rise times.

For wide-pulse applications, the AVP-AV-2-B provides output pulse widths variable from 2 to 50 ns at frequencies as high as 50 kHz. The rise time is 150 ps.

All models include an internal oscillator that is variable up to 1 MHz (to 50 kHz for AVP-AV-2-B models) using the front-panel controls. A delay control and a sync output are provided for sampling scope triggering purposes. All models can also be triggered externally using a TTL-level pulse.

Either output polarity or optional dual output polarity can be provided. Separate output ports with common pulse width and amplitude controls are provided in dual-polarity “-C” units. Only one of the two outputs is active at a time. “-B” units have a single output port, whose polarity may be switched using the front-panel controls or by computer command.

All models are available with a monitor output option that provides an attenuated (20 dB) coincident replica of

the main output pulse.

A bias insertion option is available. Units with this option include a circuit similar to Model AVX-T at the output (for details see <http://www.avtechpulse.com/bias/avx-t>). The required offset or DC bias is applied directly to rear panel solder terminals. Another option provides an internally generated DC offset (0 to ± 5 Volts), which is adjustable using the front-panel controls. Additional options include analog electronic control (0 to +10V) of output amplitude or pulse width. Units with these options also include the standard front-panel controls.

Instruments with the “-B” suffix include a complete computer control interface (for details, please see <http://www.avtechpulse.com/gpib>). This provides GPIB and RS-232 computer-control, as well as front panel keypad and adjust knob control of the output pulse parameters. A large back-lit LCD displays the output amplitude, polarity, frequency, pulse width, and delay. To allow easy integration into automated test systems, the programming command set is based on the SCPI standard, and LabView drivers are available for download at <http://www.avtechpulse.com/labview>.

-B units also include a rear-panel Ethernet connector, allowing the instrument to be remotely controlled using the VXI-11.3, ssh, telnet, and web protocols. In particular, the VXI-11.3 features allows software like LabView to control an instrument using standard VISA communications drivers and network cabling, instead of using older-style GPIB cabling and GPIB controller cards. See <http://www.avtechpulse.com/options/vxi> for details.

The -C versions do not include the GPIB, RS-232 or Ethernet interfaces (or LCD display). The output parameters are controlled by front-panel switches and one-turn controls.

All model require 100-240V, 50-60 Hz power.



SPECIFICATIONS

AVP SERIES

Model:	AVP-AV-1S-C ¹	AVP-AV-1-B ²	AVP-AV-HV2-B ²	AVP-AV-HV3-B ²	AVP-AV-2-B ²
Maximum amplitude ³ :	< 1 to 5 V	< 1 to 10 V	< 2 to 20 V	< 4 to 40 V ⁶	< 1 to 10 V
Pulse width (FWHM):	0.2 - 4 ns	0.4 - 4 ns	0.3 - 2 ns std. (0.3 - 4 ns opt ⁹)	0.4 - 2 ns std. (0.4 - 4 ns opt ⁹)	2 - 50 ns
PRF:	100 Hz to 1 MHz	1 Hz to 1 MHz			1 Hz - 50 kHz
Rise time (20%-80%):	≤ 80 ps	≤ 120 ps	≤ 120 ps	≤ 150 ps	≤ 150 ps
Fall time (80%-20%):	≤ 200 ps	≤ 300 ps	≤ 300 ps	≤ 300 ps ⁸	≤ 200 ps
Polarity:	Specify -P, -N, -PN				
Dual-Polarity Option Style:	One output, with switchable polarity.				
Required load impedance:	50 Ohms ⁷				
GPIB and RS-232 control ² :	No (not available on -C units)	Yes (standard on -B units)			
LabView Drivers:	N/A	Check http://www.avtechpulse.com/labview for downloads			
Ethernet port, for remote control using VXI-11.3, ssh, telnet, & web:	N/A	Included. Recommended as a modern alternative to GPIB / RS-232. See http://www.avtechpulse.com/options/vxi for details.			
Settings resolution (-B units):	N/A	The resolution of the timing parameters (pulse width, delay, period) varies, but is always better than 0.15% of (set value + 20 ns). The amplitude resolution is < 0.1% of the maximum amplitude.			
Accuracy / calibration:	Not calibrated. At lower pulse widths and higher PRFs, the amplitude tends to roll off relative to the set value. For high-accuracy applications requiring traceable calibration, verify the output with a calibrated oscilloscope.				
Propagation delay:	≤ 200 ns (Ext trig in to pulse out)				
Jitter, Ext trig in to pulse out:	± 35ps ± 0.015% of sync delay				
Trigger modes:	Internal trigger, or external trigger (TTL level pulse, > 50 ns, 1 kΩ input impedance)	Internal trigger, external trigger (TTL level pulse, > 10 ns, 1 kΩ input impedance), front-panel "Single Pulse" pushbutton, or single pulse trigger via computer command			
Variable delay:	Sync to main out: 0 to 200 ns, for internal trigger mode only. No variable delay in external trigger mode	Sync to main out: 0 to 1.0 seconds, for all trigger modes (including external trigger).			
Sync output:	+3 Volts, > 50 ns, will drive 50 Ohm loads				
DC offset or bias insertion:	Optional ⁴ . Apply required DC offset or bias in the range of ± 50V (250 mA max) to back panel solder terminal.				
Monitor output option ⁵ :	Provides a 20 dB (x10) attenuated coincident replica of main output				
Connectors:	Out, Monitor: SMA. TRIG, SYNC, GATE (-B only): BNC				
Optional accessory kit: (attenuators and terminators)	Add the suffix "-AK1" to the model number to include the recommended accessory kit. Consists of three SMA, 18 GHz, 2 Watt attenuators (10, 20 & 30 dB) for use on the output, and two 50 Ohm, 1 GHz, 1 Watt feed-through terminators (one SMA, one BNC) for use on external trigger inputs.				
Optional accessory kit: (coaxial cables and adapters)	Add the suffix "-AK8" to the model number to include the recommended accessory kit. Consists of one 12-inch SMA-M/SMA-M PE-SR405FL coaxial cable, one 12-inch SMA-M/SMA-M RG-316 coaxial cable, one 36-inch SMA-M/SMA-M RG-316 coaxial cable, one 24-inch SMA-M/BNC-M RG-316 coaxial cable, one 36-inch BNC-M/BNC-M RG58C/U coaxial cable, one SMA-F to BNC-M adapter, one SMA-M to BNC-F adapter, one SMA-F to SMA-F adapter, and one SMA-F to solder cup adapter				
Temperature range:	+5°C to +40°C				
Power requirements:	100 - 240 Volts, 50 - 60 Hz				
Dimensions:	100 × 430 × 375 mm (3.9" × 17" × 14.8")				
Chassis material:	Aluminum, with vinyl trim				

- 1) -C suffix indicates stand-alone lab instrument with internal clock and line powering. No suffix indicates miniature module requiring DC power and external trigger. (See <http://www.avtechpulse.com/formats> for details of the four basic instrument formats).
- 2) -B suffix indicates IEEE-488.2 GPIB and RS-232 control of amplitude, pulse width, PRF and delay (See <http://www.avtechpulse.com/gpib>).
- 3) For operation at amplitudes of less than 20% of full-scale, best results will be obtained by setting the amplitude near full-scale and using external attenuators on the output.
- 4) For externally applied DC offset option suffix model number with -OS. The

- Avtech AVX-T bias tee can also be used to obtain DC offset. For internally generated DC offset option (0 to ±5V) add the suffix -OT to the model number.
- 5) For monitor option add suffix -M.
- 6) At maximum pulse width. The maximum amplitude may fall for narrower pulse widths, with reduction of < 25% at the minimum specified pulse width.
- 7) A 50 Ohm load is required. Other loads may damage the instrument. Consult Avtech (info@avtechpulse.com) if you need to drive other load impedances.
- 8) For 0.4 - 4 ns pulse width, suffix model number with -W4. Fall times increases to 450 ps for -W4 models.
- 9) For 0.3 - 4 ns pulse width, suffix model number with -W5.



Typical -B unit (computer control ports are on the rear panel)



Typical -C unit (no computer control ports)

BASIC TEST ARRANGEMENT FOR -B AND -C UNITS

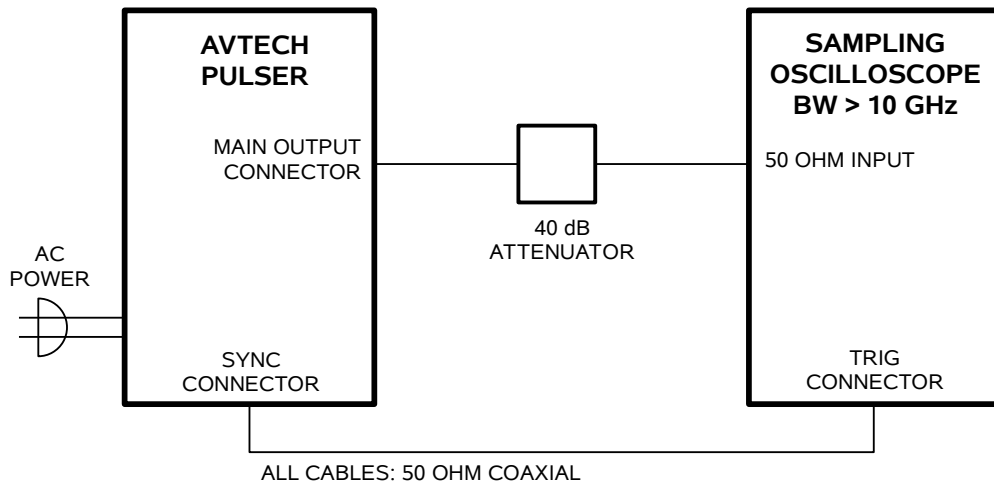

Avtech frequently customizes models to meet special requirements at near-stock prices!

Contact Avtech (info@avtechpulse.com) today with your special requirements!